

THIS DRAWING IS UNPUBLISHED. RELEASED FOR PUBLICATION
 © COPYRIGHT - By - ALL RIGHTS RESERVED.

LOC	DIST	REVISIONS					
		P	LTR	DESCRIPTION	DATE	DWN	APVD
AF	50		C3	REVISED PER ECR-14-005944	23APR2014	GRZ	JL

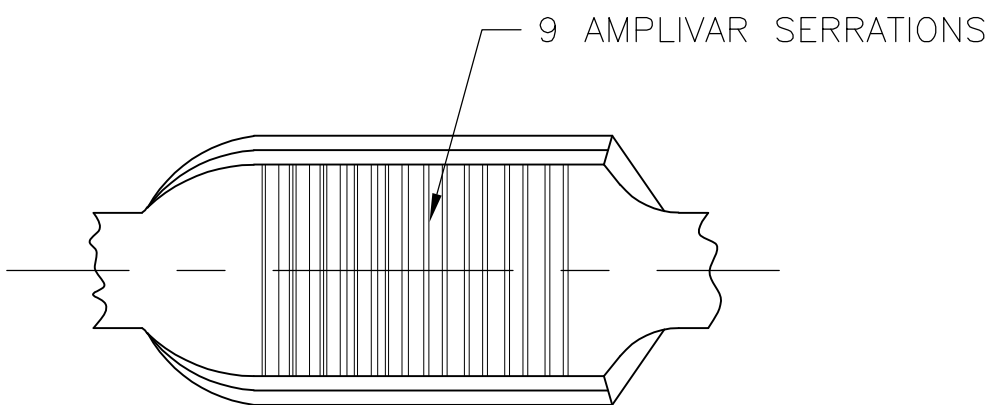

1. PRODUCT PROVIDED IN STRIP FORM ON REELS; BREAKS MAY BE PRESENT.
2. DIMENSIONS IN BRACKETS ARE IN INCHES.
3. CRIMP WIDTH: .110 F (AMPLIVAR TYPE)
 CRIMP HEIGHT ($\pm .002$) = (TOTAL CMA + 9360) / 190,400
 GENERAL APPLICATION GUIDELINES MUST BE FOLLOWED AS SPECIFIED IN CATALOG # 82221
 FOR APPLICATOR INFORMATION CALL: 1-800-722-1111
 FOR PRODUCT INFORMATION CALL: 1-800-522-6752

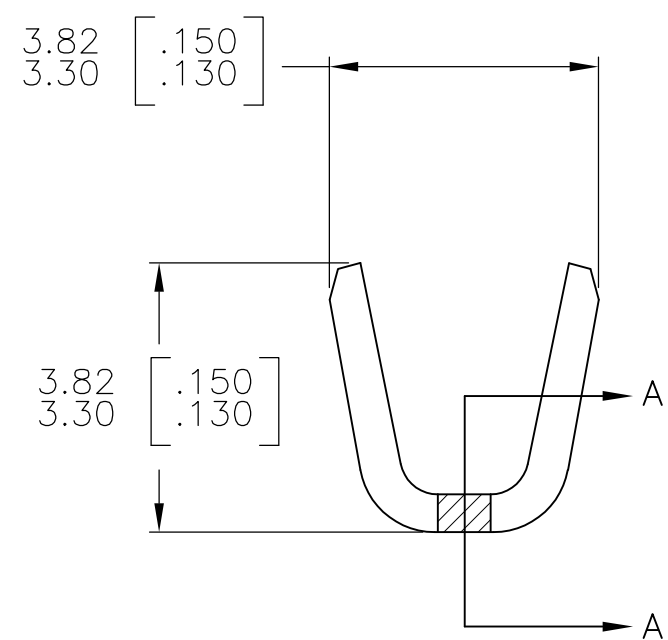
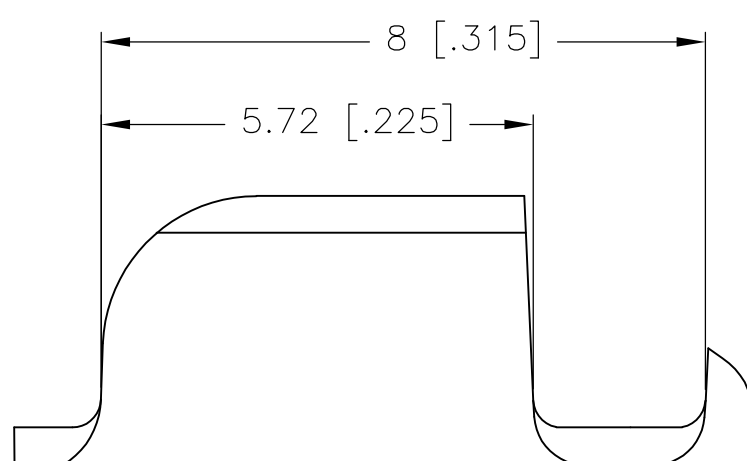

NOT FOR USE WITH ALUMINUM MAGNET WIRE,
 USE WITH COPPER MAGNET WIRE ONLY

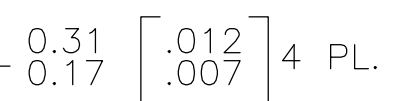
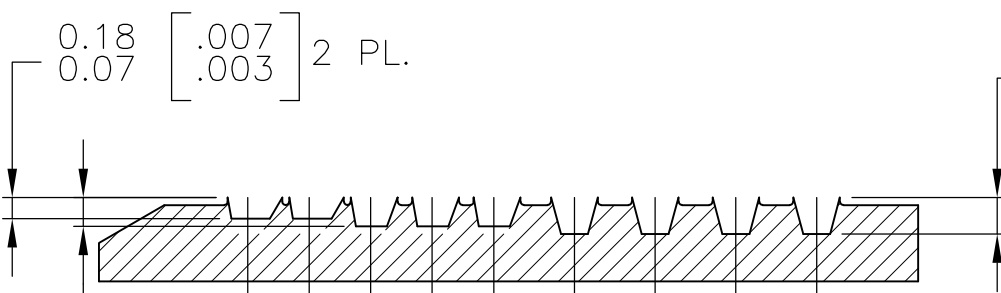

METRIC

TIN	62304-2
NONE	62304-1
FINISH	PART NO.

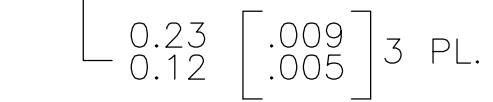

SECTION A-A
 SCALE 20:1

THIS DRAWING IS A CONTROLLED DOCUMENT.		DWN RAGHAVENDRA 27JAN06	STE TE Connectivity	
DIMENSIONS: mm [INCHES]		CHK G.D.PORTA		
TOLERANCES UNLESS OTHERWISE SPECIFIED:		APVD G.D.PORTA	NAME	
0 PLC ± -		PRODUCT SPEC	SPLICE, AMPLIVAR	
1 PLC ± -		APPLICATION SPEC	600-3000 CMA	
2 PLC ± 0.38[.015]		114-2003	SIZE	CAGE CODE
3 PLC ± -		WEIGHT -	A3	00779
4 PLC ± -		CUSTOMER DRAWING	DRAWING NO	C-62304
ANGLES ± 1°		SCALE 10:1	SHEET 1 OF 1	REV C3
FINISH SEE TABLE		RESTRICTED TO -		
MATERIAL REF 0.51±0.03 [.020±.001] BRASS				